



Installation Guide

CONTENTS

Installation	2
Mount the pan/tilt unit	2
Requirements	2
Connect the PT unit	4
Fit sunshields to all payloads	5
Attach the payloads	7
Removing a payload	9
Boresight adjustment	10
Important precautions when adjusting the boresight	11
Summary of steps when adjusting the boresight	11
Further information	13
Appendix A - Base connector pin-out	13
Appendix B - Payload side connector pin-out	14

INSTALLATION

Mount the pan/tilt unit

The PT unit must be securely mounted to a sturdy surface that is able to withstand the weight of the whole assembly, plus dynamic wind loading plus a suitable safety factor.

Requirements

- **PT unit fixings** - The compact base of the PT unit has four M8 holes and must only be used with M8 fixings that are fully rated for the task (premium grade stainless steel with high tensile strength).

Notes:

- *There is very limited space between the bottom of the PT unit body and the top of the four bolt holes (2.13" 54mm). For this reason, if inserting bolts from the top down into the mounting surface) a maximum bolt length of 50mm is possible.*
- *Note: The base of the PT unit is very compact and 'top heavy' when not secured to a surface. For this reason the unit should never be left standing upright on a surface without being secured.*
- **Pillar mount** - For best results use a three pillar mount to link the PT unit with the main mounting surface. This will allow the mounting bolts to be inserted and tightened, and also provide sufficient space and access for the main power and control connection. Connection is made via a MIL spec connector and multicore cable. The length of the connector plus the minimum bend radius of the cable mean that a minimum of 7.87" (200mm) space is required immediately below the PT unit mount.
- **Clearance** - Ensure that a clear diameter of 5' (1.5m) is maintained in all axes between the assembly and any other object.

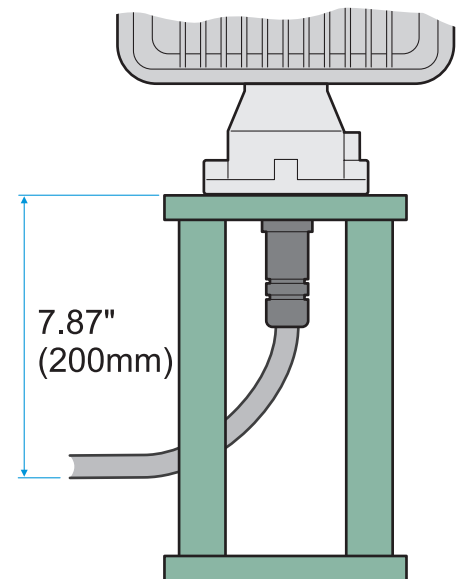
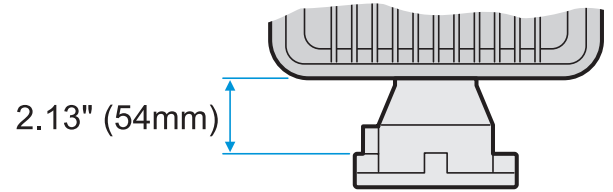

Three pillar mount

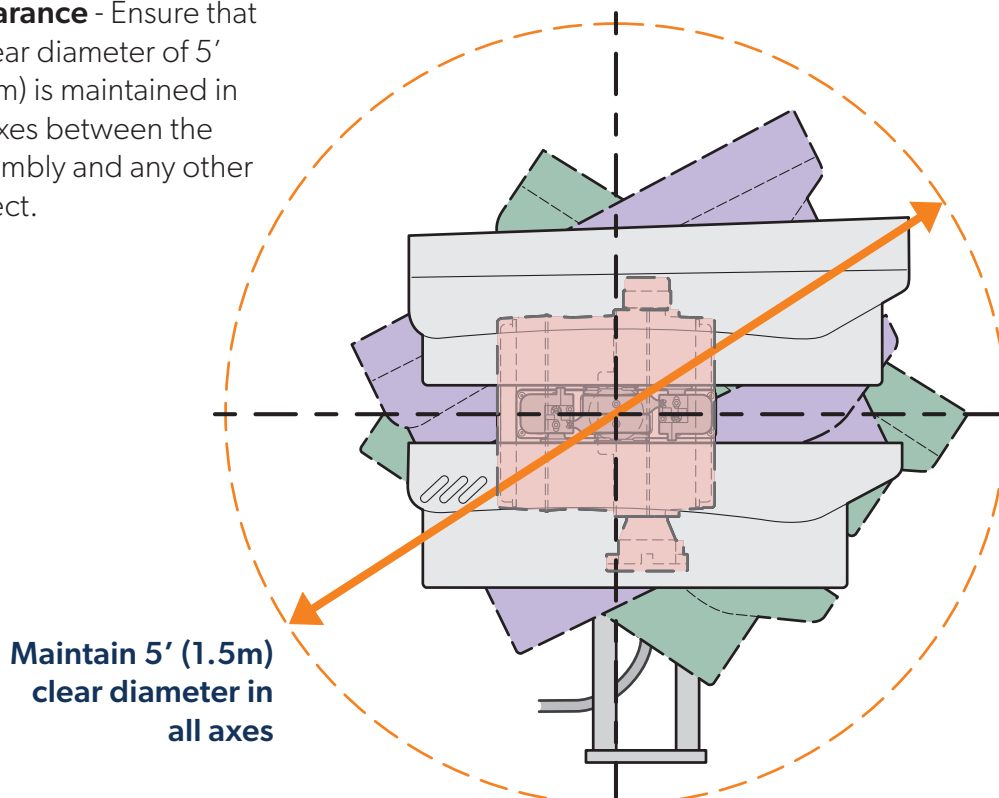

Maintain 5' (1.5m) clear diameter in all axes

PT unit eye bolts

Each PT unit is fitted with four M8 eye bolts to assist with installation.

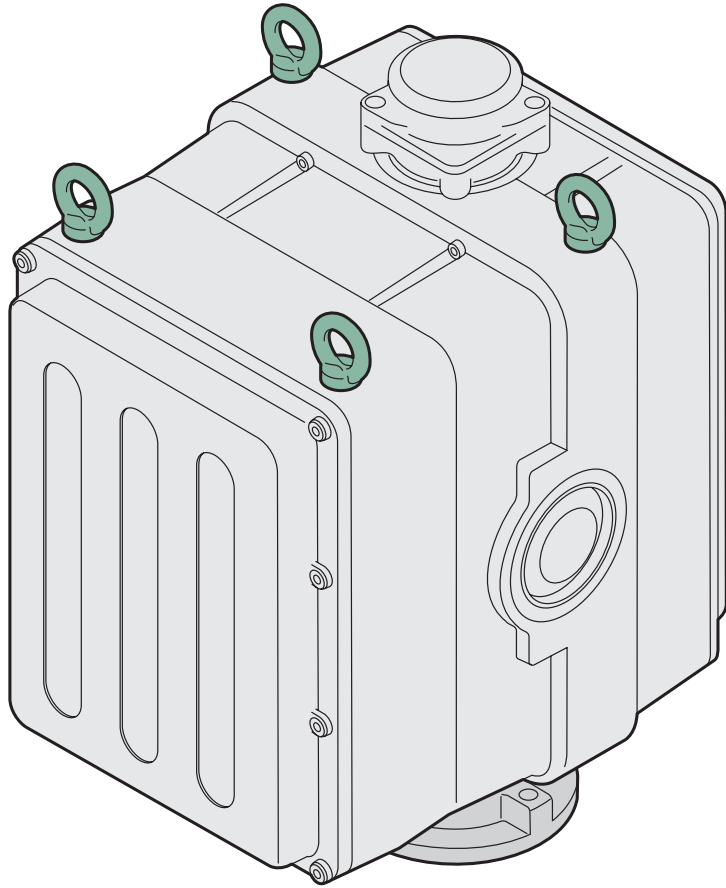

To mount the PT unit



Caution: The PT unit weighs 66 lbs (30kg). Lifting and mounting should be always completed by two people.

- 1 Lift the PT unit onto the secure mounting surface.
- 2 Insert four M8 50mm stainless steel bolts and attach washers and Nyloc® nuts.
- 3 Tighten all bolts evenly.

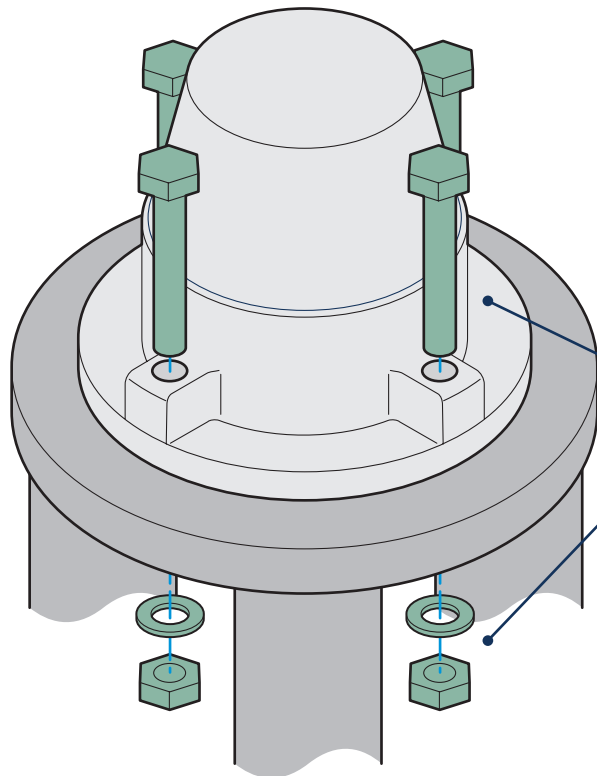

4 No premium stainless steel M8 x 50mm bolts plus washers and Nyloc nuts.

Connect the PT unit

Ensure that the main power supply is isolated.

- 1 Orientate the MIL spec connector of the main power and control feed with the socket on the underside of the PT unit base.
- 2 Engage the connector and twist the locking ring clockwise until it clicks fully into place.

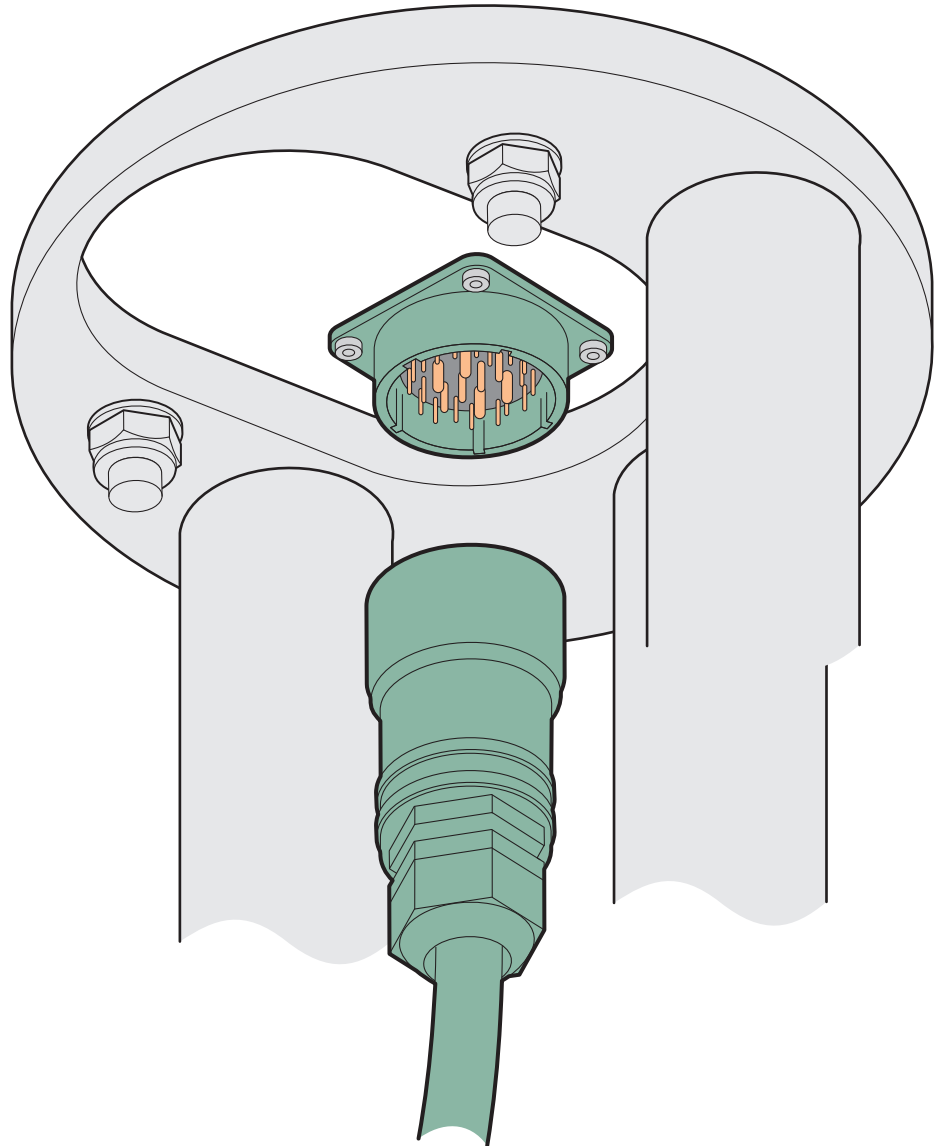

Socket spec: MIL38K

See "Appendix A - Base connector pin-out" on page 13

Fit sunshields to all payloads

To fit a sunshield to a lower level (illuminator) payload

- 1 Slide the sunshield onto the illuminator from the front and align it with the four threaded corner holes in the top of the illuminator.

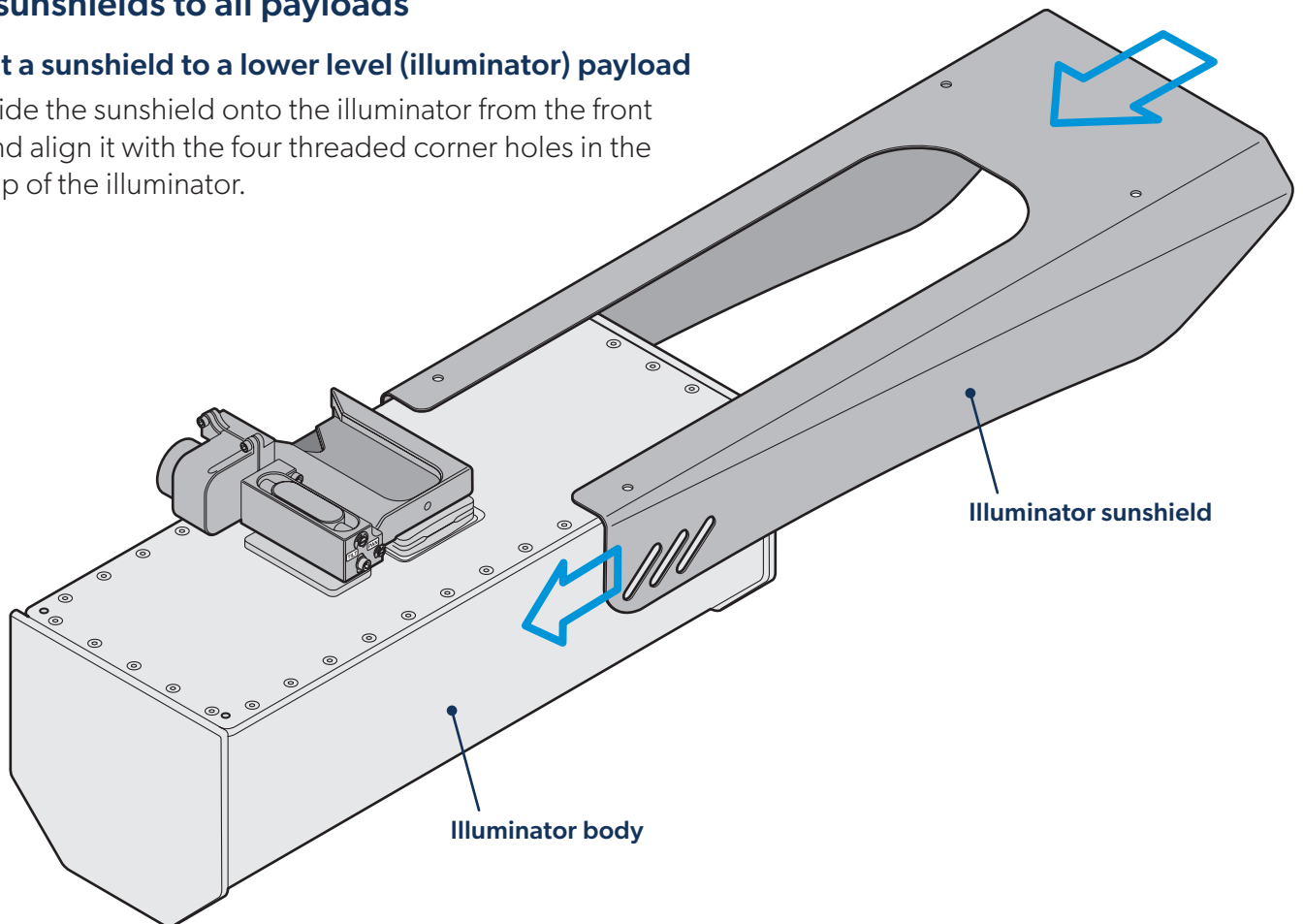

- 2 Insert the four supplied bolts and washers to secure the sunshield.
- 3 Use a 3mm hex key to tighten the four bolts. Do not overtighten.

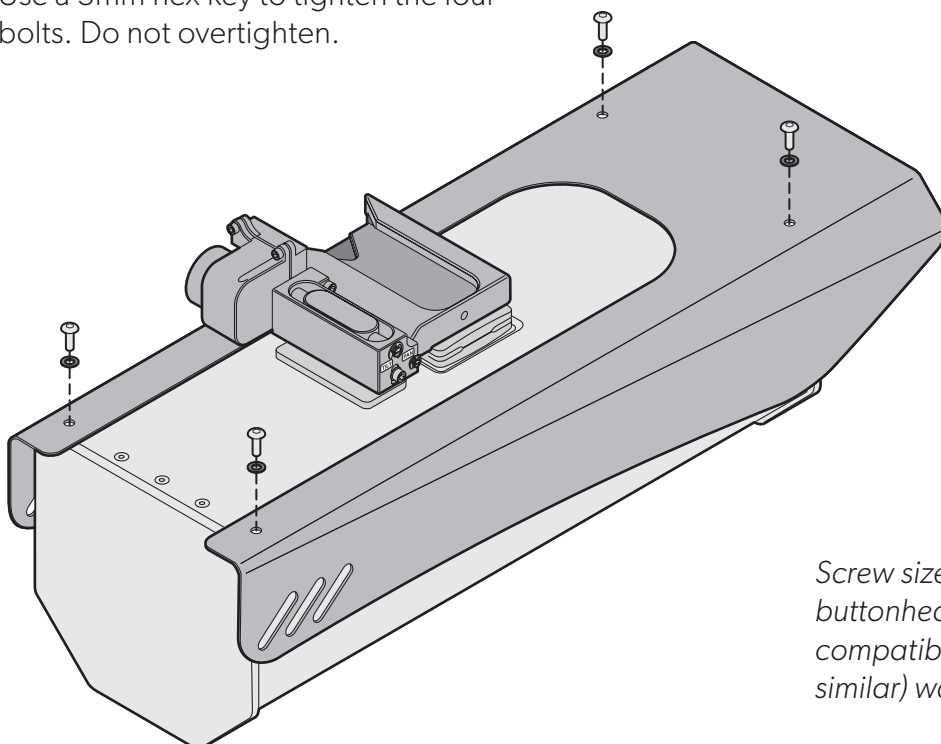

Screw size: M5 x 8mm
buttonhead with
compatible nylon (or
similar) washer

To fit a sunshield to an upper level (camera) payload

- 1 Place the sunshield over the camera and align the eight slotted holes with the threaded holes on the sides of the camera.

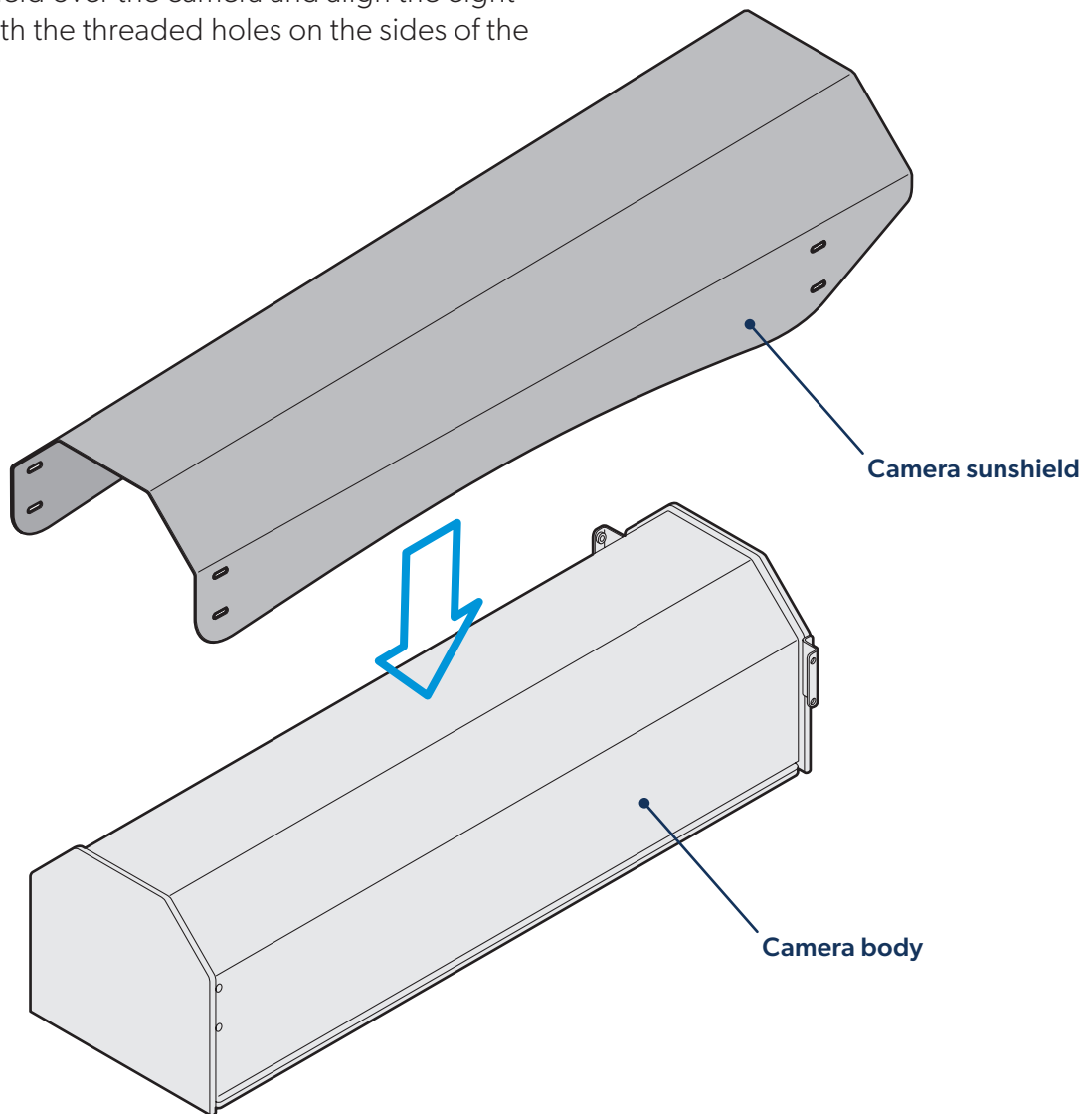

- 2 Insert the eight supplied stainless steel bolts and plastic washers to secure the sunshield.
- 3 Use a 3mm hex key to tighten the eight bolts. Do not overtighten.

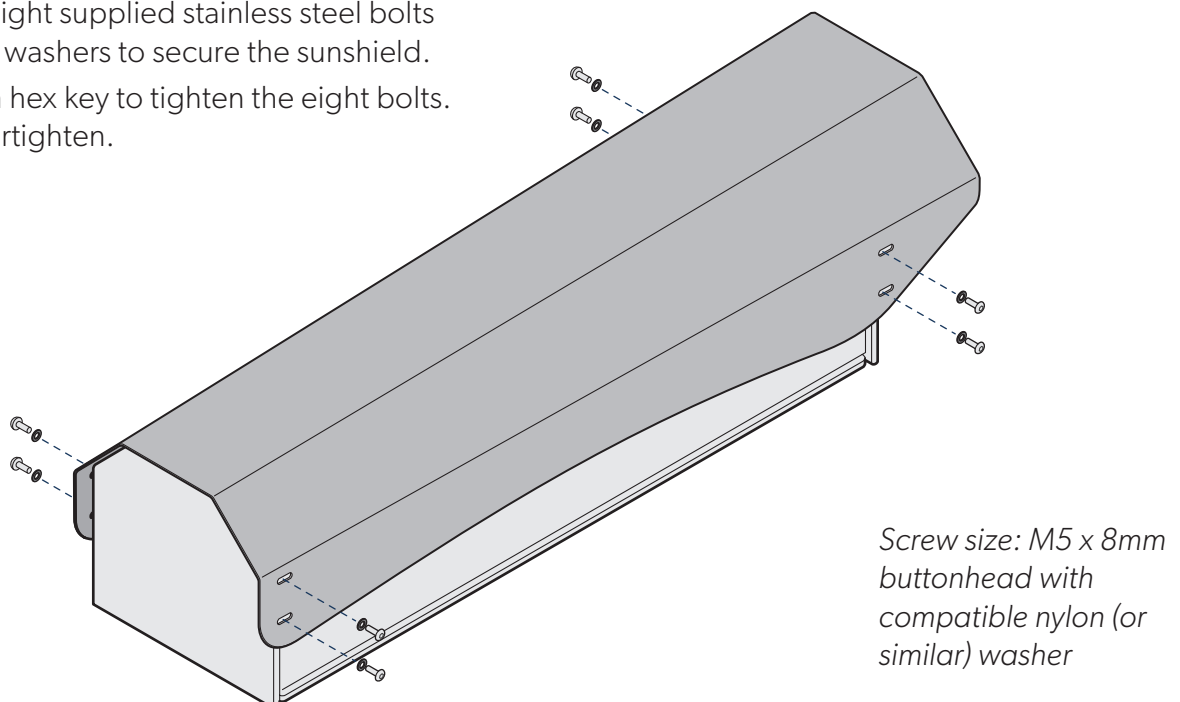

Attach the payloads

Two payloads can be attached onto each side of the PT unit, most often with a camera in the upper position and a corresponding illuminator in the lower position.

On each side of the PT unit, two payloads can be attached to the tilt arms in any order. However, it can be easier to fit the lower payload first.



Caution: Each payload can weigh up to 44 lbs (20kg). This procedure should be completed by two people, particularly in exposed conditions.

IMPORTANT: Always ensure the PT unit is isolated from its power supply before attempting to attach or detach payloads.

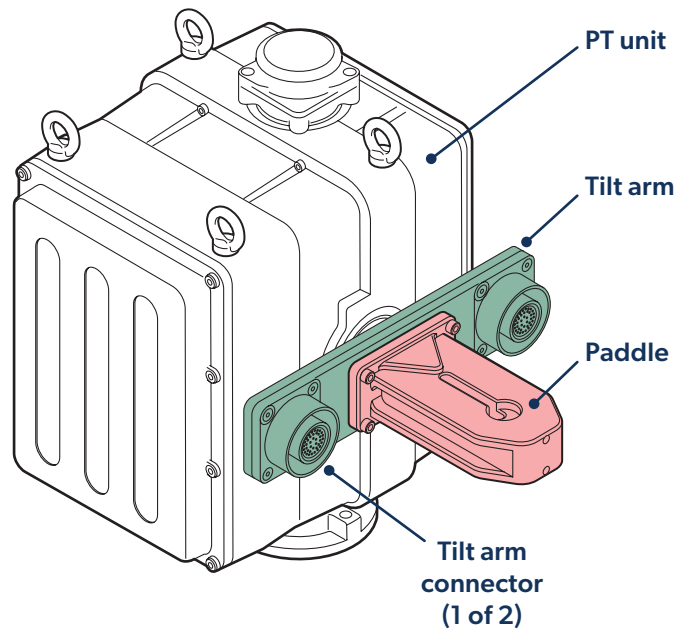

To attach a payload

- 1 Ensure power to the PT unit is isolated.
- 2 With assistance from a colleague, carefully lift the payload and line up its payload mount with the correct ribs of the paddle.
- 3 Slide the payload mount fully onto the paddle. Ensure the payload mount engages correctly with the tilt arm connector.

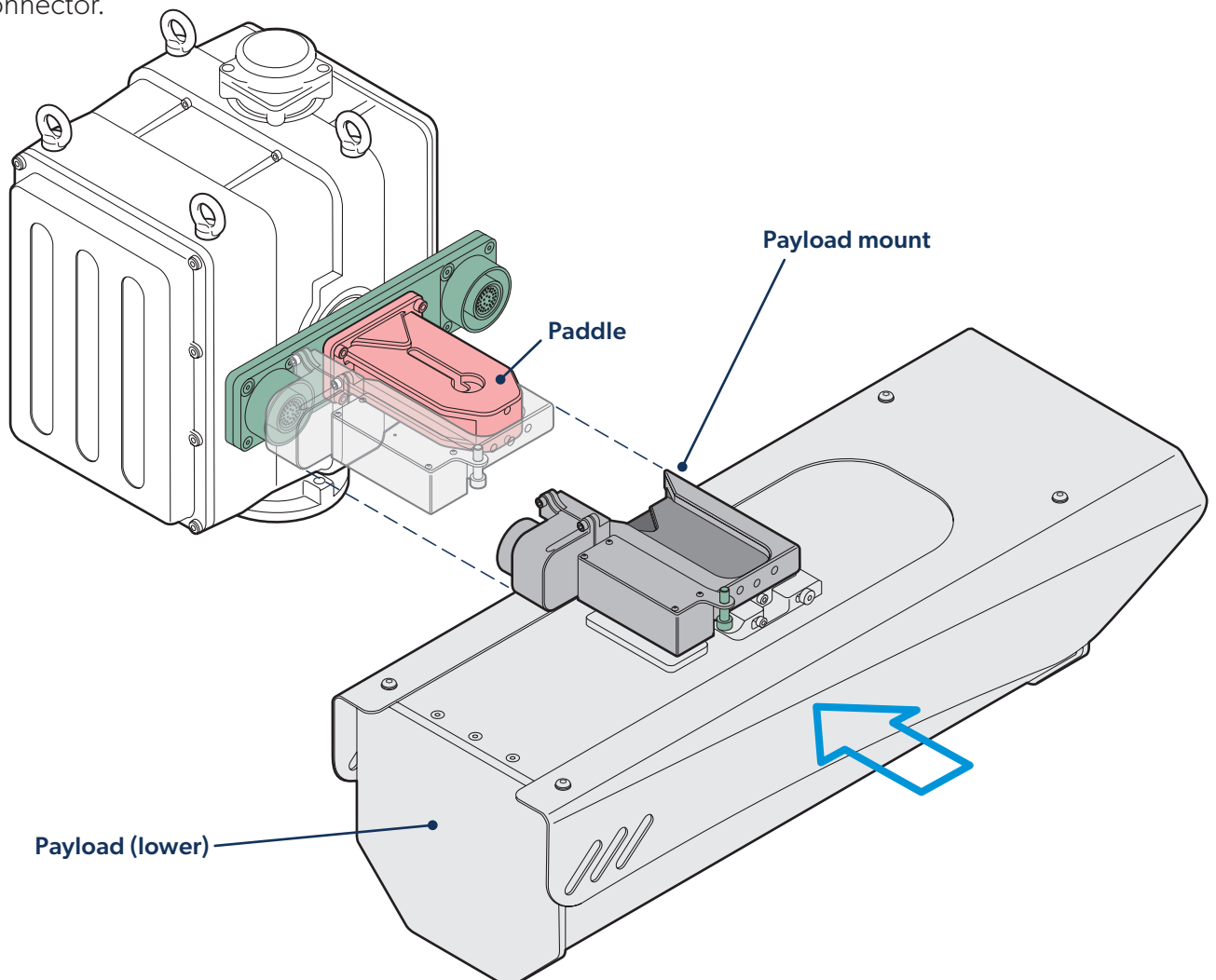

- 4 Insert the supplied locking bolt into the main section of the payload mount, where it will engage with the end of the paddle. Use a 6mm hex key to torque the bolt to hand tightness - do not overtighten.

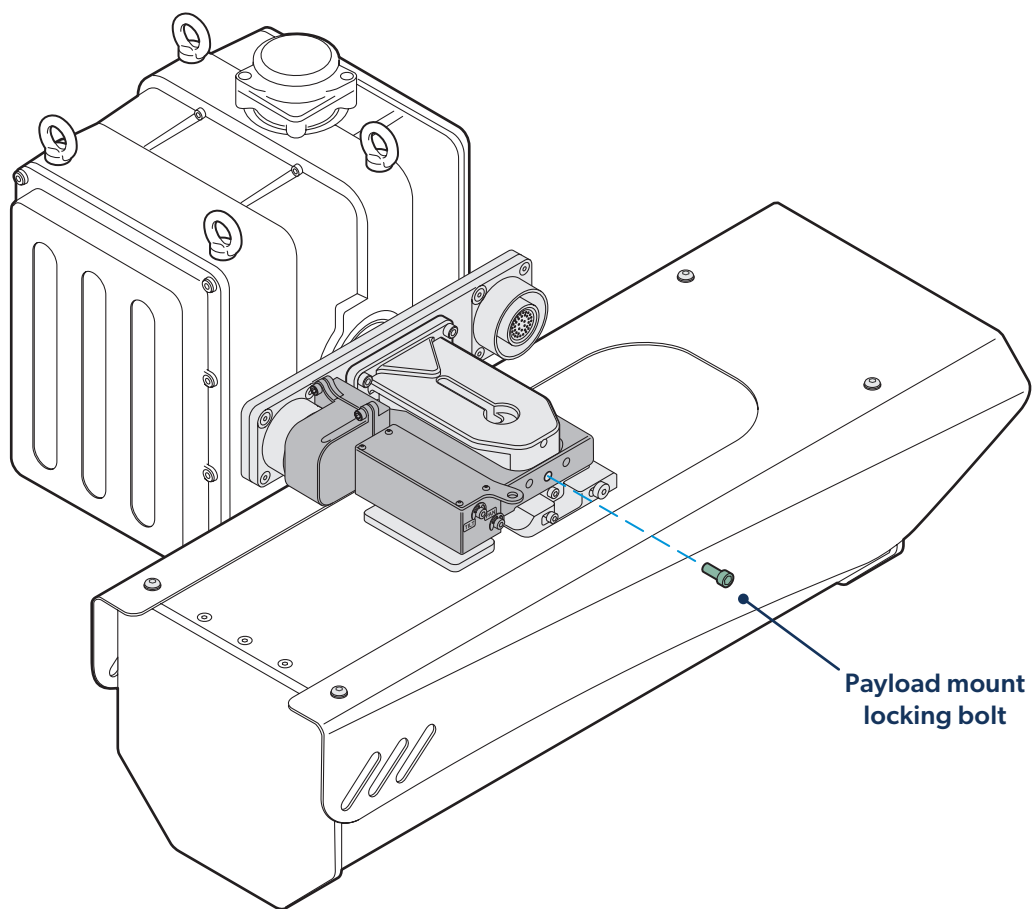

- 5 Repeat the procedure for all remaining payloads.

Removing a payload

When removing a payload it can sometimes be difficult to initially separate the payload from the paddle and tilt arm connections. To assist, you can use the lock bolt as a jack screw in order to get the payload moving.

To remove a payload

- 1 Use a 6mm hex key to remove the locking bolt from the payload mount.
- 2 Insert the locking bolt into either of the holes in the payload mount that are adjacent to the central locking hole. Use the 6mm hex key to carefully tighten the bolt so that it presses against the end of the paddle and forces the payload mount to disengage.
- 3 Carefully remove and store the payload.

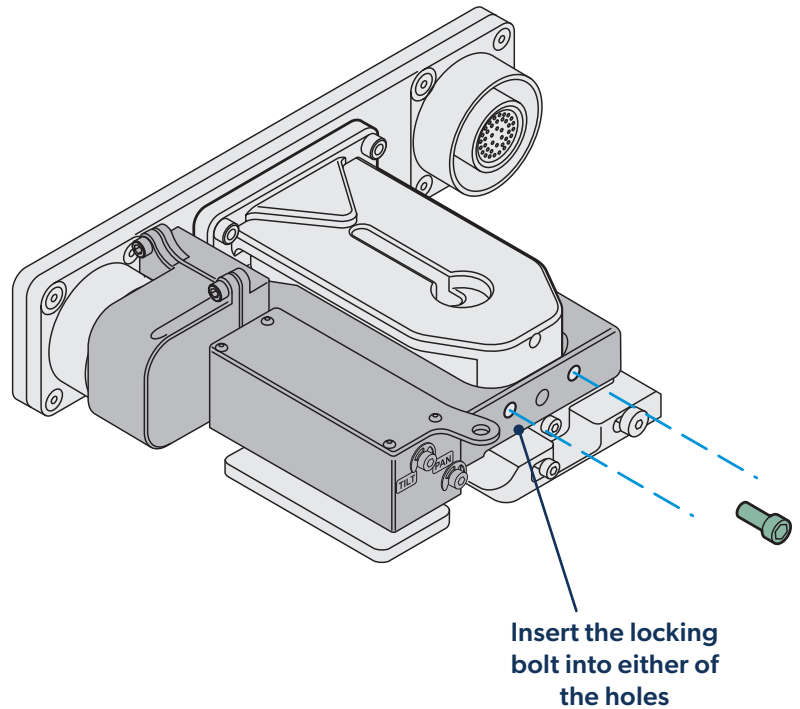

- 4 Unscrew the locking bolt from the hole and insert it in the captivation plate so that it's ready for use in the next installation.

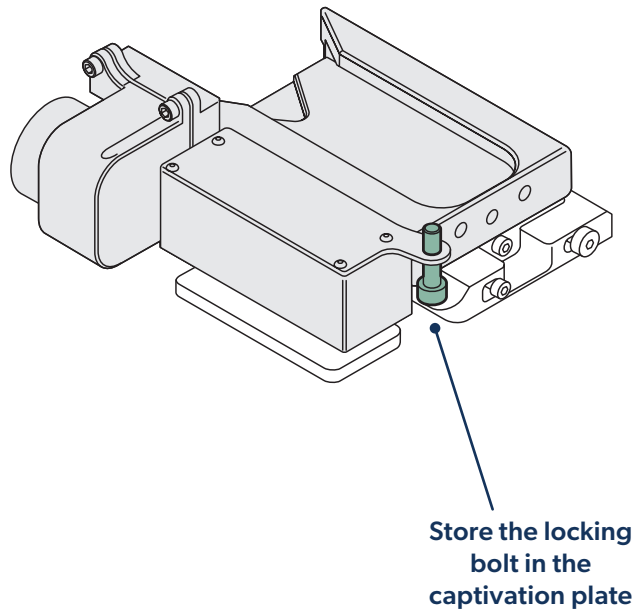

Caution: Each payload can weigh up to 44 lbs (20kg). This procedure should be completed by two people, particularly in exposed conditions.

IMPORTANT: Always ensure the PT unit is isolated from its power supply before attempting to attach or detach payloads.

Boresight adjustment

Once all of the payloads are attached and secured onto the tilt arms you will need to carry out a boresight adjustment to ensure that they are all correctly aligned with each other.

To complete this task, the PT unit and payloads will need to be operational and you will also need to view the output from both cameras.

See Important precautions on page 11.

Adjusters located on each payload mount allow you to determine the pan and tilt offsets.

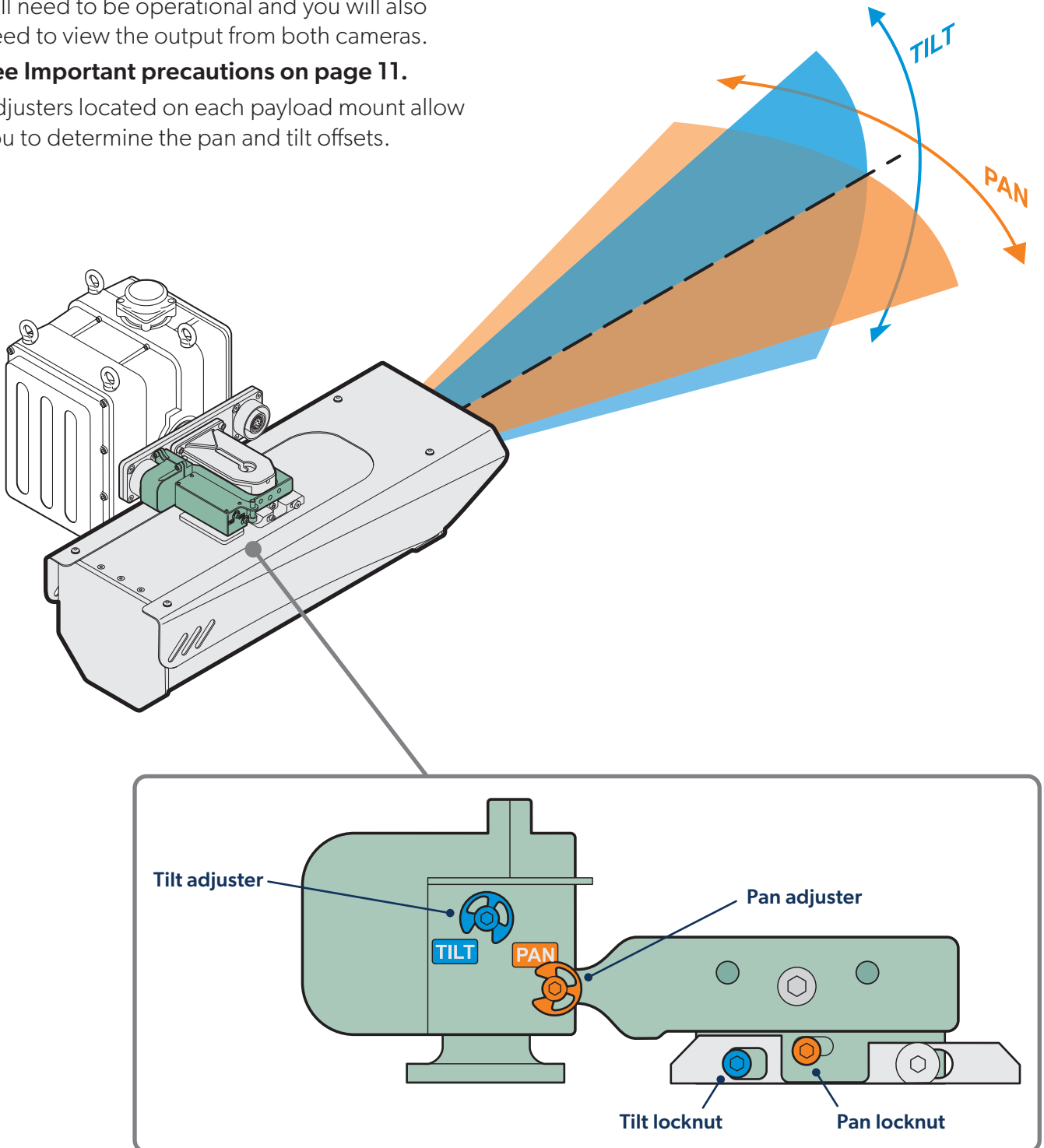

Important precautions when adjusting the boresight



When adjusting the boresight it will be necessary to work close to the installed assembly while it is powered on and functional. If possible, temporary controls should be placed next to the assembly and operated by the person working on the unit.

If this is not possible then great care must be taken that all pan and tilt movements are coordinated between the site operative and the person at the remote controls.

If necessary, use barriers and warning signs to ensure that other personnel are not endangered by the assembly.

Summary of steps when adjusting the boresight

Boresight adjustment is carried out in the following order:

- 1 Align the thermal camera and laser illuminator.
- 2 Adjust the daylight camera to align with the thermal camera.
- 3 Align the visible light illuminator with the daylight camera.

Tools required

- Hex keys (3 and 4mm)



As part of the commissioning process the laser illuminator will need to be energized.

All personnel in the vicinity of the assembly must wear certified laser safety eyewear and avoid looking directly into the laser illuminator at all times.

If necessary, use barriers and warning signs to ensure that other personnel are not endangered by laser emissions.

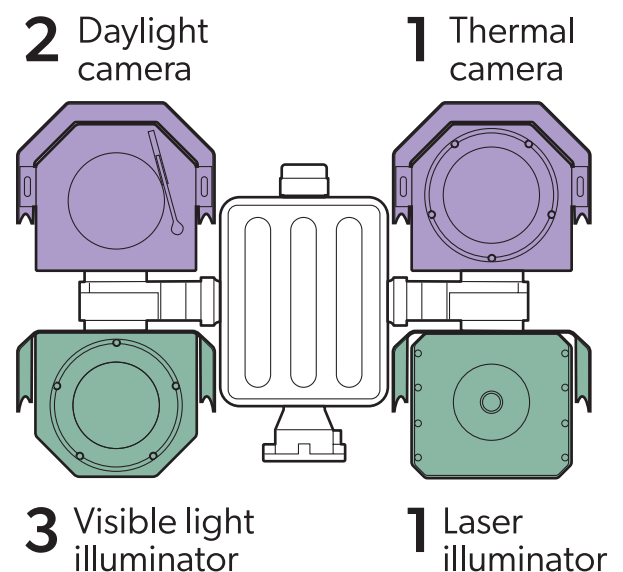

To adjust the boresight

- 1 Ensure the area around the assembly is clear of obstructions and personnel. See important precautions on page 11. Apply power to the assembly and check that all of the basic functions (pan, tilt, zoom and imaging) are operating and correctly responsive to the controls.
- 2 As discussed on page 11, the thermal camera is operated first. Take the thermal camera to its highest zoom level and focus on a distant location. Once set, do not change the pan and tilt positions during this process.
- 3 Energize the laser illuminator and view its effect on the thermal display. Use the adjustment screws (of the laser illuminator payload mount) to align the laser illuminator with the center of the thermal image. See **Pan and tilt adjusters** below.
- 4 Take the daylight camera to its highest zoom level and view how the center of its display relates to the corresponding distant location shown on the thermal display. Use the adjustment screws (of the daylight camera payload mount) to align the center of the daylight camera with that of the thermal image. See **Pan and tilt adjusters** below.
- 5 Energize the visible light illuminator and view its effect on the daylight camera. Use the adjustment screws (of the visible light illuminator mount) to align the illuminator with the daylight camera image. See **Pan and tilt adjusters** below.

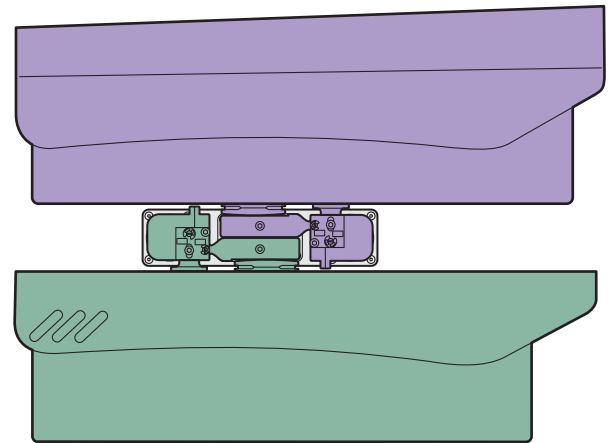

Payload mounts for upper and lower payloads

Pan and tilt adjusters

- Use a 3mm hex key to loosen the locknut for the required pan or tilt axis.
- Use a 4mm hex key to turn the associated adjuster screw as you observe the positional change in the camera view. The screws adjust each axis position as follows. Because the payload mounts for the upper payloads are inverted, their effects are similarly inverted:

Pan

Screw turn	Upper payload	Lower payload
Clockwise	Pan right	Pan left
Counter clockwise	Pan left	Pan right

Tilt

Screw turn	Upper payload	Lower payload
Clockwise	Tilt down	Tilt up
Counter clockwise	Tilt up	Tilt down

- When the adjustment is correct, use the 3mm hex key to hand tighten the associated locknut.

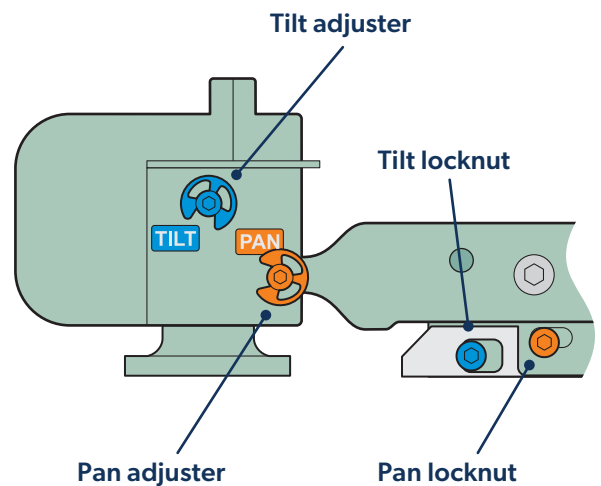

FURTHER INFORMATION

Appendix A - Base connector pin-out

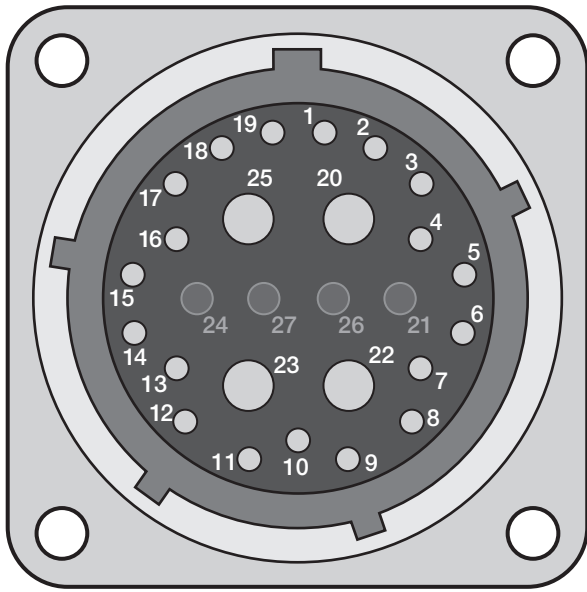

Note: Ethernet wiring allocations are based on the TIA-568B standard.

Male socket

Pin	Function	Conductor
1	Ethernet B1	Brown
2	Ethernet B2	White/Brown
3	Ethernet B3 (Rx-)	Green
4	Ethernet B4 (Rx+)	White/Green
5	Ethernet B5	Blue
6	Ethernet B6	White/Blue
7	Ethernet B7 (Tx-)	Orange
8	Ethernet B8 (Tx+)	White/Orange
9	Telemetry (D+)	Yellow
10	Telemetry (D-)	Blue
11	Chassis/Earth	Green/Yellow stripe
12	Ethernet A1	Brown
13	Ethernet A2	White/Brown
14	Ethernet A3 (Rx-)	Green
15	Ethernet A4 (Rx+)	White/Green
16	Ethernet A5	Blue
17	Ethernet A6	White/Blue
18	Ethernet A7 (Tx-)	Orange
19	Ethernet A8 (Tx+)	White/Orange
20	PTZ power positive (48VDC)	Red
20	PTZ power positive (48VDC)	Orange
21	N/C	
22	Power DC (through)	Brown
23	Power DC (through)	Blue
24	N/C	
25	PTZ power negative (48VDC)	Black
25	PTZ power negative (48VDC)	White
26/27	N/C	

Appendix B - Payload side connector pin-out

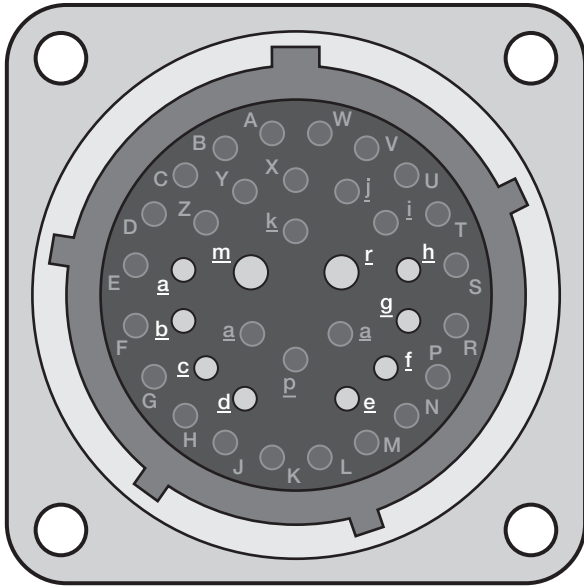

Female socket

Pin	Function	Conductor
a	Ethernet 1	Brown
b	Ethernet 2	White/Brown
c	Ethernet 3	Green
d	Ethernet 4	White/Green
e	Ethernet 5	Blue
f	Ethernet 6	White/Blue
g	Ethernet 7	Orange
h	Ethernet 8	White/Orange
m	Payload power positive	Brown
r	Payload power negative	Blue
Chassis	Earth	Green/Yellow

All other contacts: N/C